

# Owner's Manual for the **SILENT PARTNER** Ball Machine



## **SAFETY FIRST**

THE SILENT PARTNER BALL MACHINE IS CAPABLE OF THROWING TENNIS BALLS AT HIGH SPEED. TAKE ALL NECESSARY PRECAUTIONS TO PREVENT THROWN BALLS FROM STRIKING PEOPLE.

DO NOT ALLOW CHILDREN TO USE THE MACHINE AND KEEP THEM AT A SAFE DISTANCE FROM IT WHEN ON COURT.

WALKING IN FRONT OF THE MACHINE DURING OPERATION CAN CAUSE A SERIOUS ACCIDENT.

DO NOT INSERT YOUR HANDS OR ANY FOREIGN OBJECTS INTO THE OPENINGS OF THE MACHINE WHILE IT IS RUNNING.

EXERCISE CAUTION WHEN CARRYING THE MACHINE. CARELESS LIFTING CAN RESULT IN INJURY.

# THE CONTROL PANEL OF THE SILENT PARTNER

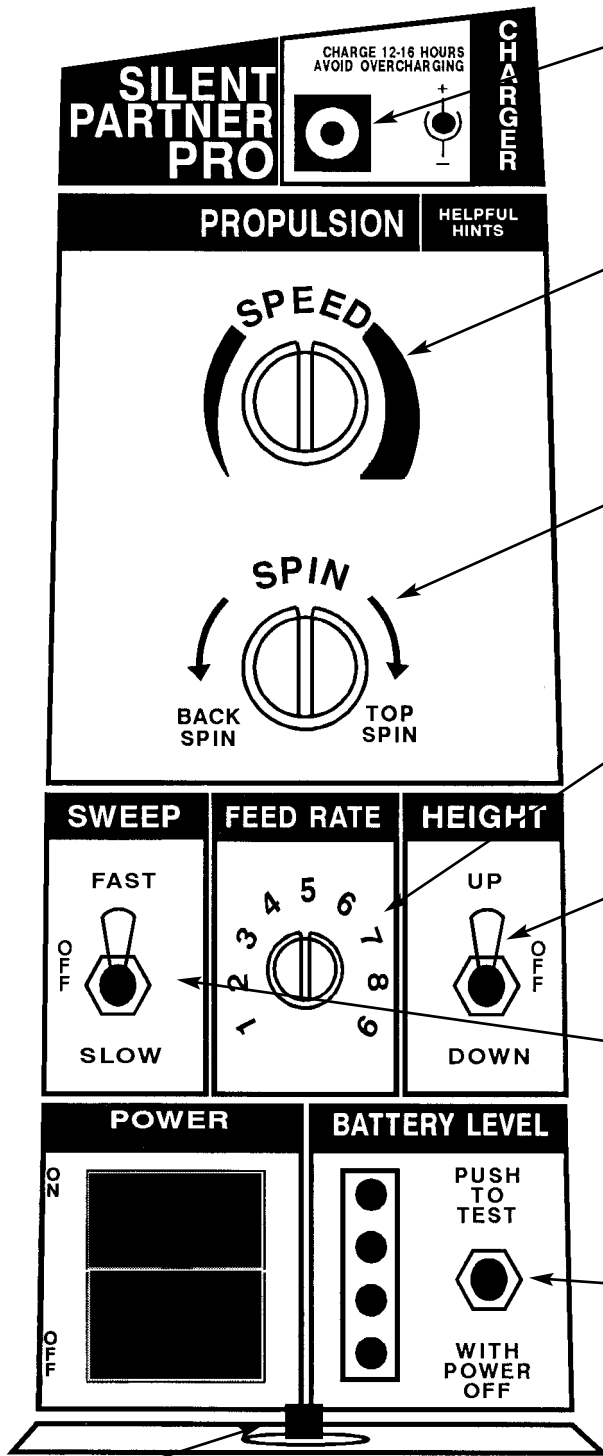

### BATTERY CHARGER JACK

The Silent Partner is delivered with a battery charger that mounts in ordinary wall outlets. It takes about 12 to 16 hours to charge the batteries in the machine. Avoid charging for longer than 24 hours.

### SPEED CONTROL

Ball ejection speed can be adjusted from a soft toss to a challenging drive. Settings in the top range produce unusually high speeds. For consistent ball throws, use fully pressurized balls. Pressureless balls can also be used to avoid pressure loss over time.

### SPIN CONTROL

A simple turn of this knob will generate spin varying from slice to top spin. Spin is generated by the relative speed of the two propulsion wheels. Positioning the knob in the mid-position produces "flat" (spinless) ball throws.

### FEED RATE

Feed rate can be adjusted from very slow to about one ball every second.

### ELEVATION (PRO model only)

The height of ball throws can be adjusted with the machine off. Avoid starting the machine in the lob position since balls can easily be shot outside the court.

### SWEEP (SPORT and PRO models only)

To simulate recreational play with an opponent, set the sweep control on "SLOW". A more vigorous workout is achieved in the "FAST" position. To achieve symmetrical court coverage, ensure that the lower platter of the machine is aligned with the court.

### BATTERY CHARGE

Pressing this button will reveal the level of battery charge. For accurate readings, the machine must be off and the battery charger disconnected. The top light indicates a full charge. Lights go off in sequence as charge drops. When all lights are off, watch carefully for a drop in propulsion speed. Stop play as soon as you observe a marked slow down.

### RESET BUTTON

The sophisticated electronic circuitry of your Silent Partner is protected by a reset button located at the base of the control panel. If the reset button pops during play, check for obstructions of the propulsion wheels. The most likely cause of failure is a ball stuck behind the propulsion wheels. Never use wet balls in the machine!

FOR YOUR CONVENIENCE, IMPORTANT HINTS ARE PRINTED ON THE CONTROL PANEL. TAKE GOOD NOTE OF THEM!

## RANDOM OSCILLATOR (SPORT and PRO only)

3

When using the oscillator, begin by aligning the machine with the court by insuring that the lower platter is "square" with the court (the lower platter is the aluminum piece to which the rubber feet are attached. Its front edge must be parallel to the baseline). This will ensure that the machine will swing equally to the left and right.

The oscillator rate can be set on "HIGH" or "LOW" at the control panel.

The Silent Partner should ordinarily be placed at the baseline. To increase the angle of sweep, locate the machine closer to the back fence. To decrease the angle of sweep, locate the machine closer to the service line.

## REMOTE CONTROL (PRO only)

The Silent Partner PRO is supplied with a two-function remote control that operates ball FEED (on/off) and SWEEP (on/off).

Because the performance of the remote control is influenced by the terrain where it is located and by interference from other sources, the range of operation can vary substantially.

If reception fails, change locations slightly or move closer to the machine.

A common cause of poor remote performance is a weak battery in the hand-held unit.

The FEED function only works when the machine is turned on at the control panel.

The SWEEP function only works when SWEEP is set to FAST or SLOW at the control panel.

The remote control resets itself every time the machine is turned off. The reset default is with FEED and SWEEP in the "on" position so that the machine can be used in the absence of the transmitter.

**BECAUSE OF THE EXCESSIVE COST OF SHIPPING AND HANDLING, DEUCE INDUSTRIES LTD. DOES NOT SUPPLY REPLACEMENT BATTERIES FOR THE REMOTE CONTROL UNIT. YOU CAN OBTAIN THESE BATTERIES AT RADIO SHACK (PART #: 23-144) AND OTHER ELECTRONIC SUPPLIERS.**

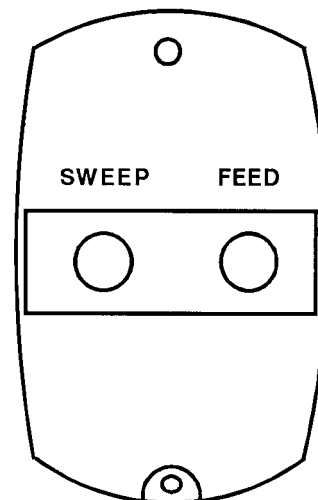

This device complies with Part 15 of the FCC rules. Operation of this device is subject to the following two conditions: 1. This device may not cause harmful interference. 2. This device must accept any interference received, including interference that may cause undesired operation.

## FOR BATTERY-POWERED MODELS ONLY

### BATTERY CHARGING

Your Silent Partner is delivered with a battery charger that plugs into standard AC outlets and connects to the machine at the panel. Always ensure that the AC outlet is live and that all connections are secure.

- A full charge requires 12 to 16 hours.
- Charge the battery immediately after each use.
- The battery does not need to be drained in order to be charged.

#### FOR MAXIMUM BATTERY LIFE:

- 1) Avoid discharging batteries excessively (stop playing as soon as you notice the speed of the ball drop)
- 2) Charge soon after running the batteries down.
- 3) Do not charge much beyond a full charge.

Note that the panel gauge is only accurate when the machine is off and the battery charger is disconnected. The top light on the gauge indicates a full charge and normally goes off soon after the machine is used.

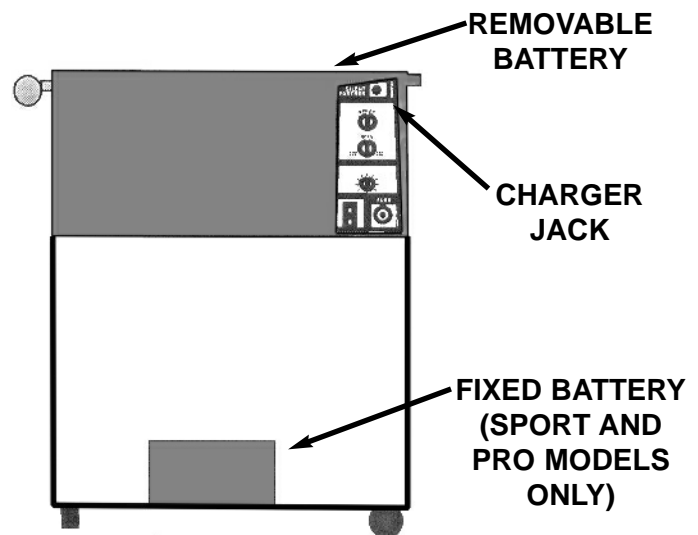

**TO MAXIMIZE BATTERY LIFE, AVOID CHARGING BATTERIES FOR LONGER THAN 24 HOURS**

### BATTERY SWAPPING

Always turn the power switch to "OFF" when changing the top battery.

The battery compartment is located under a cover at the top of the machine. You can access the battery by unscrewing the thumb screw and sliding the cover out of position.

Lift the battery carefully and allow it to rest in a position that gives you access to the battery terminals. Disconnect the red and black wires gently. Hold the wire terminals when disconnecting. Do not pull on the wires themselves.

When connecting a spare battery to the machine always ensure that the red wire is connected to the positive terminal of the battery and the black wire to the negative terminal. The battery terminals show the polarity (+ and -) and are color-coded in the same way as the machine wires. Reversal of wires at the battery can result in serious damage to the electronics of the Silent Partner when the machine is turned on.

## ELEVATION (PRO)

The height of the path of the ball above the net can be adjusted from a low drive to a lob. On the PRO, exceptionally high elevation can be achieved by pushing the carrying handle all the way down, thus causing the entire machine to tilt backwards.

To adjust elevation on the Silent Partner PRO, push the switch at the panel in the "UP" or "DOWN" position until the desired ball trajectory is achieved.

The elevation adjustment occurs electronically as a motor causes changes in the inclination of the arm that carries the propulsion wheels.

To achieve very high lobs, begin by adjusting the electronic elevation mechanism to its highest throwing position. You can then push the carrying handle all the way down (see instructions on multifunction carry handle).

When the handle snaps into its lowest position, the entire Silent Partner will be tilted backwards slightly, thus adding to the angle of throw.

Note that the machine cannot oscillate when it is in this incline position.

**ELECTRONIC ELEVATION**

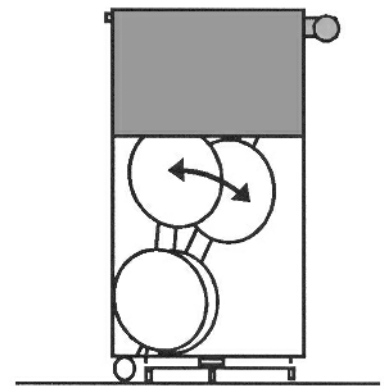

**HANDLE TILT**

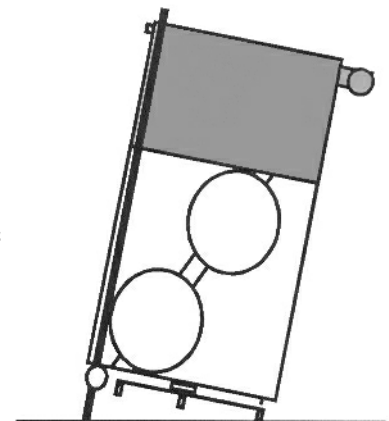

## ELEVATION (ULTRA LITE and SPORT)

To adjust the height of the trajectory of the ball on the manual models, unfasten the clamp located to the side of the machine and position it in the appropriate location along the arc of adjustment. Fasten the clamp snugly before starting to play.

To practice overheads place the elevation control at the extreme right, position the machine near the back fence and set the spin control to backspin.

**SLIDE AND CLAMP**

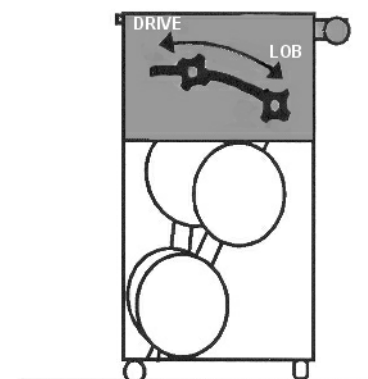

## THE HANDLE OF THE SILENT PARTNER PRO

FULLY EXTENDED

1 CLICK DOWN

2 CLICKS DOWN

3 CLICKS DOWN

PLAY POSITION



When installing the handle on new machines, take note of the orientation of the release buttons. They must be inserted so that they are accessible as shown in the picture on the left.

## HANDLE OF THE SPORT AND ULTRA LITE

The Silent Partner Sport and Ultra Lite are equipped with a swing handle that is attached to the rear of the machine. To roll, lift the handle and pull the machine.

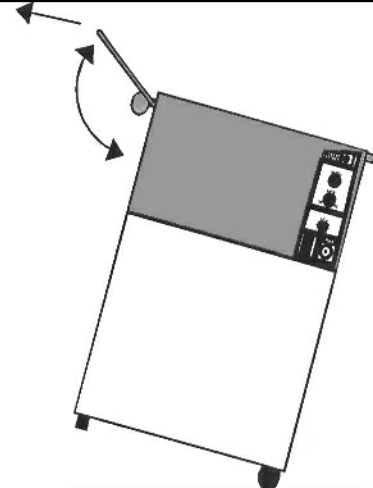

## THE HOPPER

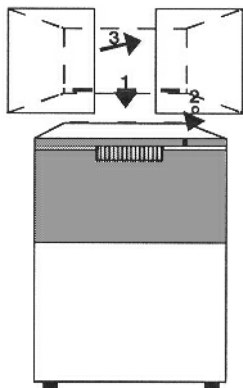

To install the hopper for play, spread the open side and follow the three steps shown in the figure:

- 1) Engage the three tabs at the front of the machine.
- 2) Engage the metal pin at the back of the machine.
- 3) Press the loose panel on the Velcro strip.

To store the hopper for portability, reverse the three installation steps then wrap the hopper around the bottom of the machine, and secure it into position by engaging the Velcro strip. The acorn nuts at the front of the machine serve as a rest for the hopper.

# CONSISTENCY OF BALL DELIVERY

## FEED CONSISTENCY

Feed consistency refers to the delivery of balls at a regular interval. Feed consistency is determined by the consistency with which balls are picked-up by the "carousel". You can do two things to promote feed consistency:

- 1) Avoid overfilling the hopper.
- 2) Push balls towards the front of the machine as shown.

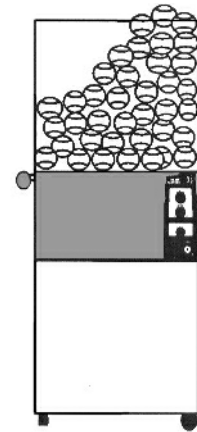

## THROW CONSISTENCY

The main reason for inconsistency in ball throws is that dead balls are not thrown as fast as firm balls. Some brands of pressureless balls are also not thrown as fast as new pressurized balls.

For best results, do not mix different types of balls or balls that differ in firmness.

# MAINTENANCE

The Silent Partner requires very little maintenance. The bearings for all motors are lubricated for life and no electronic adjustment is required.

Maintenance for the Silent Partner consists primarily of the following preventative measures:

- 1) Remove dirt from inside the machine by wiping the base with a damp cloth through the ejection hole .
- 2) On the PRO model, clean the threads of the elevation rod if you notice an accumulation of ball fuzz on it, then lubricate it with light oil. This operation is performed through the ejection hole. Avoid getting lubricant on the propulsion wheels.
- 3) The propulsion wheels are covered with a urethane dressing that does not require maintenance. When throwing balls at high speed, yellow fibres can transfer from balls to the surface of the wheels. Although these fibres do not interfere with the performance of the machine, they can be scraped or picked off the surface of the wheels.

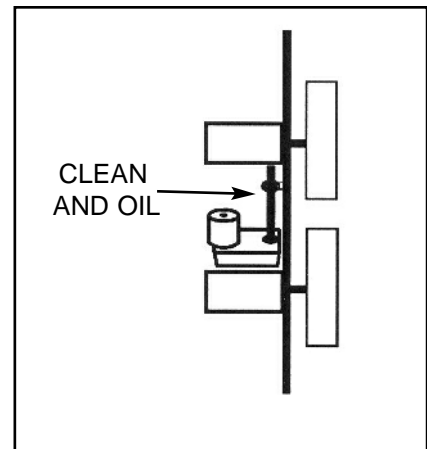

## PROGRAMMABLE OSCILLATOR OPTION

When using the oscillator, begin by aligning the machine with the court by insuring that the lower platter is "square" with the court (the lower platter is the aluminum piece to which the rubber feet are attached. Its front edge must be parallel to the baseline). This will ensure that the machine will swing equally to the left and right and that the two position knobs will aim in the intended direction.

TO COVER THE ENTIRE WIDTH OF THE COURT, PLACE THE MACHINE AS NEAR THE BACK FENCE AS NECESSARY.

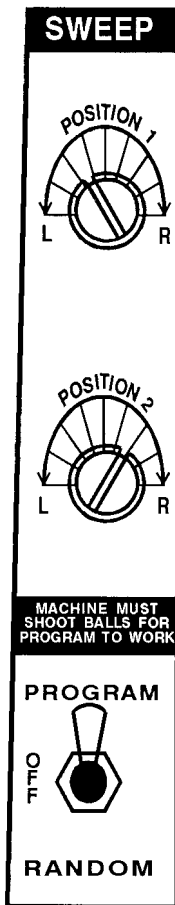

### PROGRAM MODE

When the toggle switch is set to the "PROGRAM" position, the Silent Partner will deliver balls in two locations in sequence. The two locations are set by adjusting the knobs labeled "POSITION 1" and "POSITION 2" on the control panel. Each of these knobs gives access to the entire width of the court. Note that knob positions outside the range labeled "L" (for left) and "R" (for right) are not operative.

TO ALLOW THE MACHINE TO REACH SET POSITIONS BETWEEN BALLS, AVOID EXCESSIVE FEED RATES.

### RANDOM MODE

When the toggle switch is set to "RANDOM", the Silent Partner will deliver balls in random locations within the range set by the adjustment knobs labeled "POSITION 1" and "POSITION 2" on the control panel. For easier practice, set the two knobs to define a narrow delivery range. For more challenging practice set the two knobs to define a wider range.

IT IS SOMETIMES NECESSARY ON START-UP IN THE RANDOM MODE TO OPERATE THE TOGGLE SWITCH MORE THAN ONCE.

IN PROGRAM MODE A TRIP SWITCH LOCATED IN THE PATH OF THE BALL SIGNALS THE MACHINE TO SEEK THE NEXT POSITION. FOR THIS REASON THE MACHINE MUST BE SHOOTING BALLS FOR THE PROGRAM FEATURE TO WORK.

## **Accessories**

### **Ball Machine Cover**

Fits all Silent Partner machines. Installs with the hopper on the machine.

This cover provides weather protection and allows balls to be kept safely in the hopper when the machine is stored.

The cover is dark blue and provides an attractive way to store the machine on or off the court.

Although the cover provides weather protection, it is not designed to withstand heavy rainfalls or winter conditions.



### **Extra Battery**

The upper battery in all battery-powered Silent Partner ball machines, can be removed and swapped with a fresh battery.

This 12 Volt 7.2 Amp hour sealed lead acid battery can be purchased from Silent Partner or from suppliers of sealed lead acid batteries in your area.

When properly cared for, batteries will last three or more years (see page 4 of this manual).

Instructions on how to replace the lower battery on the Silent Partner PRO and SPORT are available at: [www.sptennis.com/service](http://www.sptennis.com/service)



### **External Charger**

This charger is equipped with color coded alligator clips and permits charging batteries outside the machine. Otherwise it is identical to the charger supplied with the machine. Available only in the USA and Canada.



### **AC-DC Converter**

This accessory is only available in the US and Canada when the machine is initially purchased as an AC-DC machine. It cannot be used with a battery powered machine since internal modifications are required for the use of the converter.

Owners of machines equipped with this converter should note that the batteries in the machine are not recharged when the converter is connected to the machine. The batteries should be topped up every six months with the charger that plugs into the panel of the machine.



## TROUBLESHOOTING SIMPLE PROBLEMS

**WE POST SERVICE INSTRUCTIONS ON OUR WEB SITE.  
PLEASE CONSULT [WWW.SPTENNIS.COM/SERVICE](http://WWW.SPTENNIS.COM/SERVICE)**

### **SHORT BATTERY LIFE**

On a warm day, an intermediate player should expect about 1.5 to 2 hours of battery life whereas a beginning child might get up to four hours. Battery life drops dramatically at lower temperatures. If you suspect that you are not getting as much time out of the batteries as you should, check wire connections at the posts of the upper and lower battery (if installed) .

### **MACHINE DOES NOT RUN**

Begin by checking if the reset button has popped. If so, push it down after investigating the cause of the problem (most likely balls preventing the propulsion wheels from turning). Next, on battery powered machines, checking the level of charge of the batteries by pressing the red button on the panel. On AC machines, make sure that the outlet the machine is plugged into is live.

### **OSCILLATOR MOVES ERRATICALLY**

Check that the rolling wheels on the machine are not dragging on the court during oscillation. Excessive wear on the front rubber feet caused by dragging when rolling the machine can cause the front wheels to touch the court. Worn rubber feet can be "raised" by placing a metal washer under them. This will restore proper height at the rolling wheels.

### **CAROUSEL DOES NOT TURN**

Check that the feed control knob is turned to at least the midpoint of the scale. You can try to turn the carousel by hand (gently): if the carousel turns without engaging the motor, call the factory (1-800-662-1809).

### **REMOTE CONTROL DOES NOT WORK**

The remote control consists of a transmitter (small hand held device) and a receiver (installed in the machine). Problems of reception are usually caused by a weak battery in the transmitter (note that the red light on the transmitter is not a battery level indicator). Replacing the battery with a fresh one from Radio Shack (**PART #: 23-144**) should be the first step in diagnosing transmission problems.

### **SPEED OR SPIN CONTROL NOT NORMAL**

If the reset button is reactivated repeatedly or if static discharge is excessive under playing conditions, it is possible for electronic components on the circuit board to be affected. Uncontrollable excessive propulsion speed or spin is often an indication of this. In such cases it is best to call the factory for instructions (1-800-662-1809).

# A LOOK INSIDE THE MACHINE

WE POST SERVICE INSTRUCTIONS ON OUR WEB SITE.  
PLEASE CONSULT [WWW.SPTENNIS.COM/SERVICE](http://WWW.SPTENNIS.COM/SERVICE)

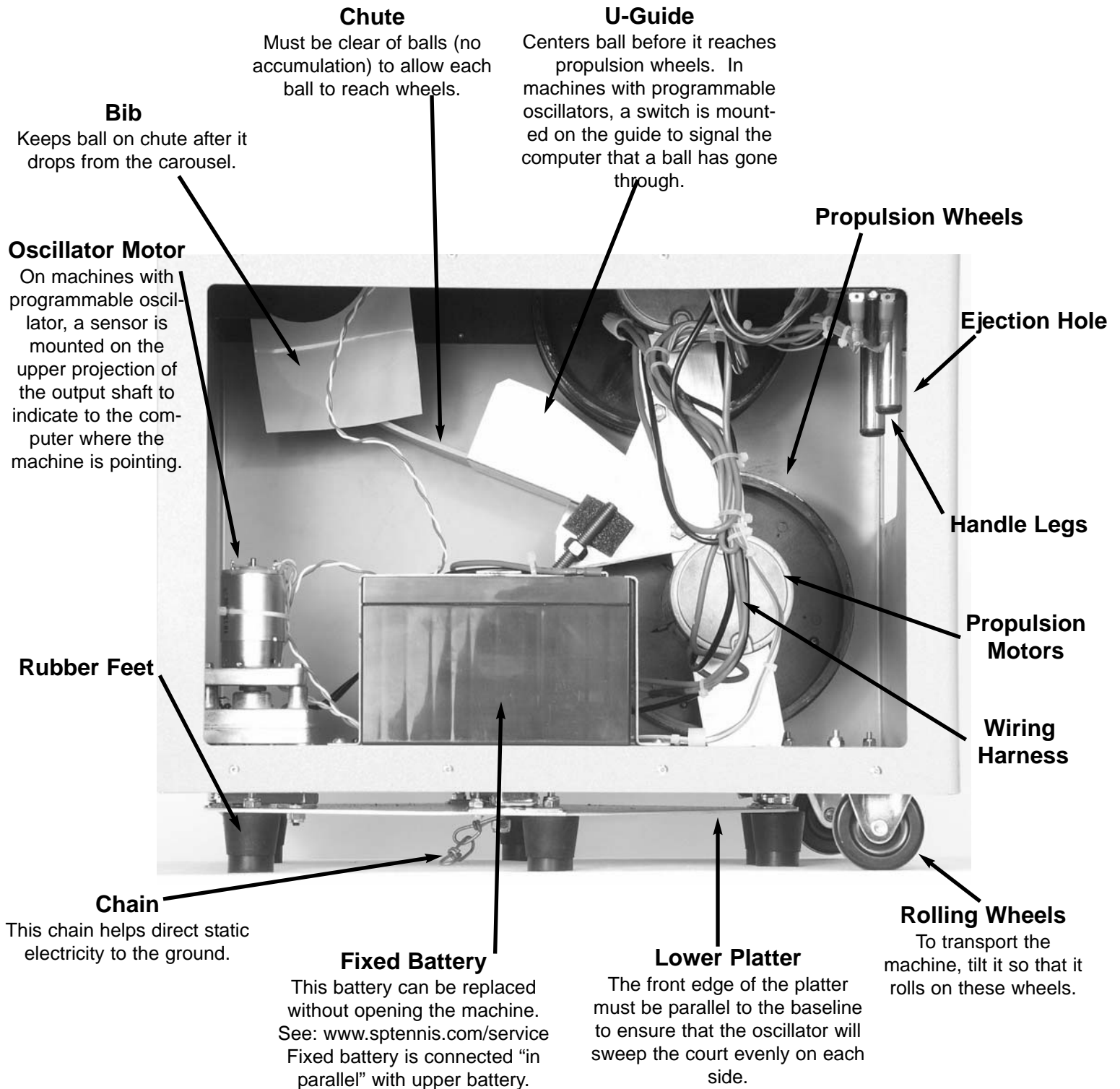

## LIMITED WARRANTY

(Valid only for machines in the United States and Canada)

Deuce Industries warrants Silent Partner ball machines for a period of one year from the date of original purchase. The warranty covers defects in the material and workmanship.

Deuce Industries' obligation under this warranty is limited to the original purchaser and applies to the cost of labor and materials to repair a warrantable defect.

To obtain warranty service, call or write Deuce Industries Ltd. to obtain instructions on how to proceed. No returns will be accepted without prior authorization.

Shipping to Deuce Industries must be prepaid. After completing warranted repairs, Deuce Industries will pay for return shipment to you.

This warranty does not cover the following:

- Units damaged by neglect, accident, abuse, or unauthorized repair or modification.
- Units subjected to damage by failure to follow instructions contained in the owner's manual.
- Units that fail following repair by anyone not authorized by Deuce Industries.
- Units damaged during shipment (present claims to shipper).

All implied warranties, including fitness for a particular purpose and merchantability are limited in duration to the length of this warranty. Deuce Industries Ltd. neither assumes nor authorizes any representative or other person to assume for it any other liability in connection with the sale or shipment of its products.

This warranty shall not be extended beyond its original term with respect to any part(s) repaired or replaced by Deuce Industries.

Under no circumstances shall Deuce Industries be liable for any consequential damage for breach of this warranty or of any implied warranty. Deuce Industries is not responsible for incidental or consequential damage of any kind. Its liability is limited to the repair or replacement, at its option, of a defective product.

## DEUCE INDUSTRIES LTD

Phone: 1-800-662-1809 Fax: 1-416-284-8271

Head Office: (not for shipping)  
500 Coronation Drive Unit 10  
Scarborough, Ontario  
Canada M1E 4V7

Office in USA:  
2221 Kenmore Ave. Unit 106  
Buffalo, NY 14207  
USA